

WH01

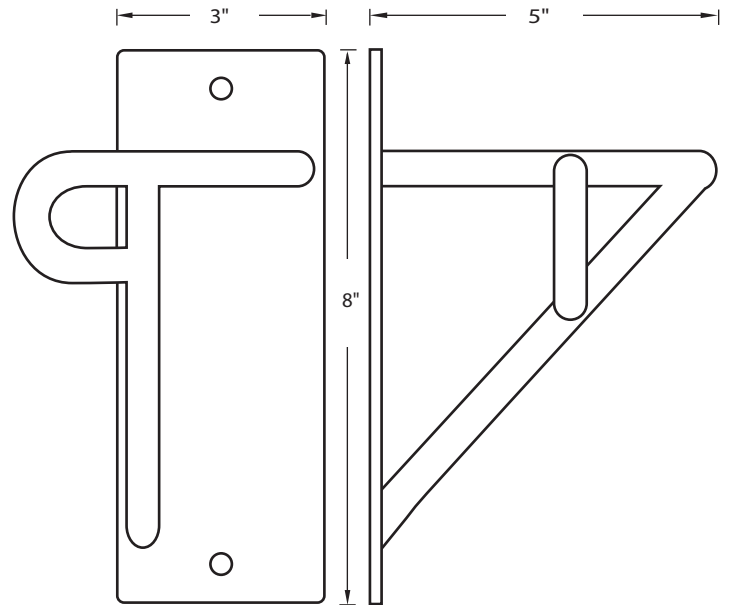

Front

Side

Specifications

- ◆ 2 mounting holes ideally accept 3/8 inch fasteners
- ◆ Recommended rack spacing; 16 inch min. w/ vertical stagger
- ◆ Vertical stagger should be 10 inches
- ◆ Ground to top of rack should be 68 inches for first rack
- ◆ Ground to top of second rack should be 78 inches
- ◆ Allow 1 foot before your first rack and beyond your last rack
- ◆ Use proper expansion bolts or Rawl Spikes for concrete wall
- ◆ If not attached to studs, add 5/8" plywood backing
- ◆ finish is powder coat black
- ◆ overall dimensions, 8" x 3" x 5"
- ◆ hook, brace, and U-piece made of 3/8 inch solid round dowel
- ◆ base plate consists of 12 gauge sheet metal
- ◆ 1 year Standard Manufacturer's Warranty

Options

- ◆ available with attached 5 foot security cable, looped end
- ◆ available with attached 30 inch hex chain, 3/8 diameter, hardened

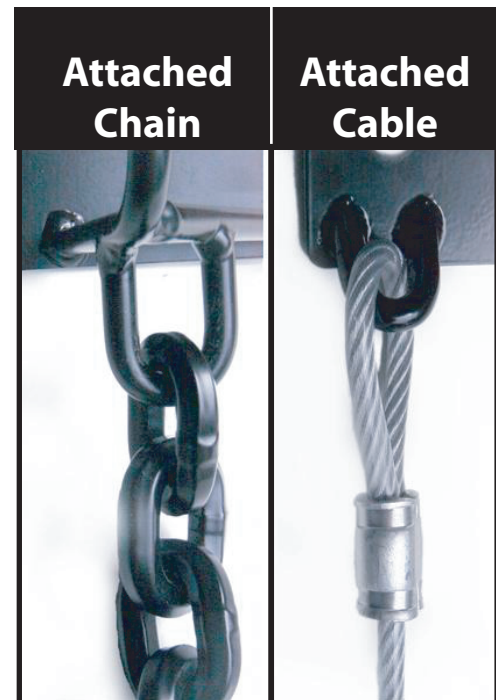

WHHX01

WHCA01